



Application

Commonly, these fans have been designed for local ventilation. They are installed on wall brackets inside the buildings (indoor application). As they can overcome significant air flow resistances, they are particularly efficient within the systems of local exhausts. The appliances meet the requirements of the ErP 2009/125/EC Directive.

Structure

The fan consists of a spiral steel housing, motor. The aluminium radial impeller is directly installed at the motor shaft. The impeller blades cross-section reminds the profile of an aeroplane wing, providing low acoustic pressure level. The fan inlet is equipped with a flange to install it on wall bracket or, directly on a filtering unit.

The outlet is ended with a round ferrule to fasten safely a spiral-seam conduit (rigid duct) or to make flexible connections. For safety reason, the inlet and outlet are equipped with a protective grill. It is recommended to install a TK silencer at the fan inlet and outlet (for details see catalogue page "Installation Elements").

On demand, we deliver isolating switches to cut off the power supply during the servicing and installing activities (see catalogue page "Electrical Accessories").

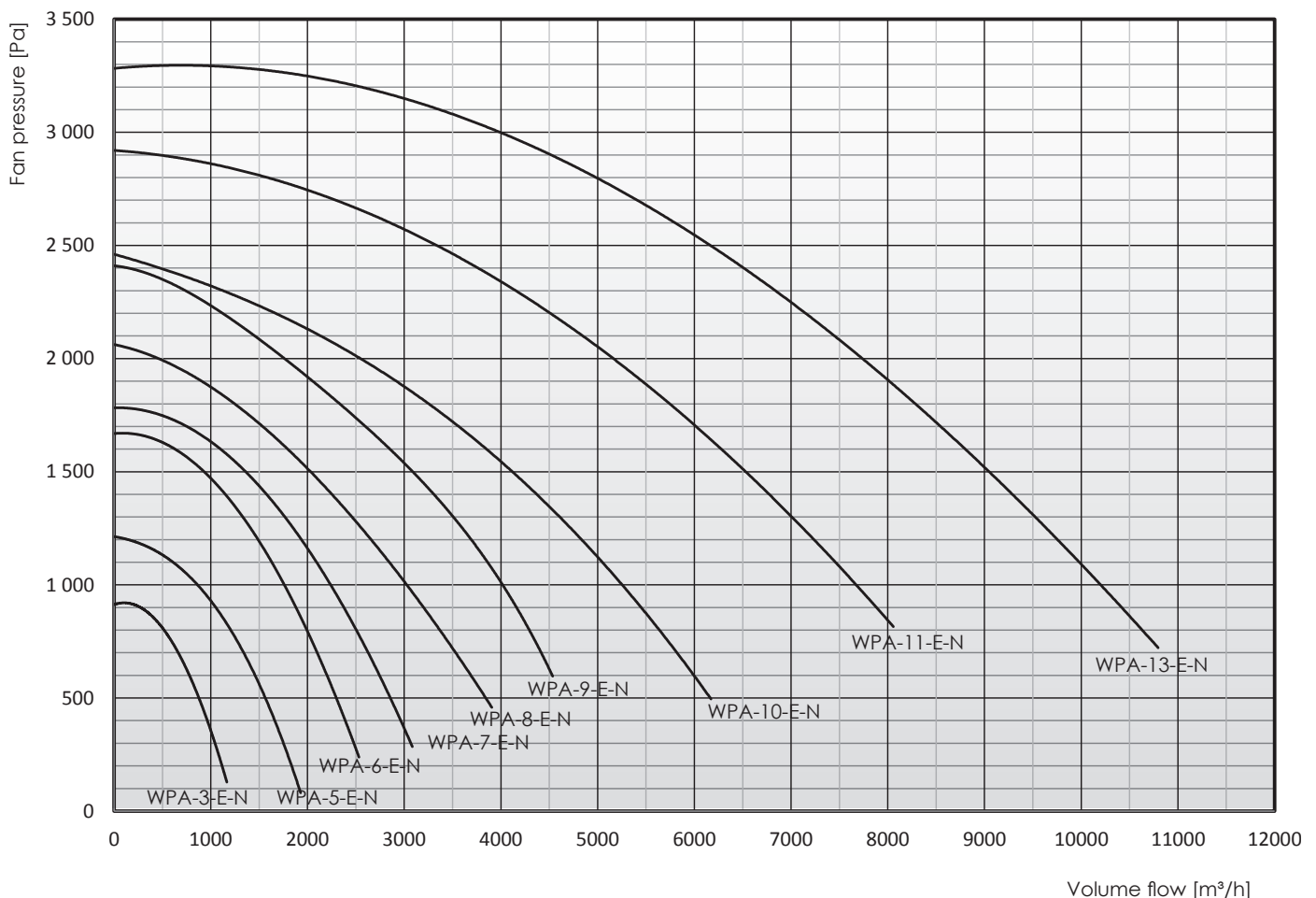



Technical Data

Type	Part.No	Synchronous rotations [1/min]	Supply voltage [V]	Motor rate [kW]	Ingress protection IP	Acoustic pressure level [dB(A)] from the distance of		Maximum volume flow [m ³ /h]	Maximum vacuum [Pa]	Weight [kg]
						1 m	5 m			
WPA-3-E-1-N	804W00	3000	230	0,37	54	78/70*	64/56*	1160	940	14
WPA-3-E-3-N	804W14	3000	3x400	0,37	54	78/70*	64/56*	1160	940	14
WPA-5-E-1-N	804W01	3000	230	0,55	54	76/67*	62/53*	1900	1250	17
WPA-5-E-3-N	804W02	3000	3x400	0,55	54	76/67*	62/53*	1900	1250	
WPA-6-E-1-N	804W03	3000	230	0,75	54	83/75*	69/61*	2500	1700	21
WPA-6-E-3-N	804W04	3000	3x400	0,75	54	83/75*	69/61*	2500	1700	
WPA-7-E-1-N	804W05	3000	230	1,1	54	86/74*	72/60*	3100	1800	23
WPA-7-E-3-N	804W06	3000	3x400	1,1	54	86/74*	72/60*	3100	1800	
WPA-8-E-3-N	804W07	3000	3x400	1,5	54	88/78*	74/64*	3900	2050	29
WPA-9-E-3-N	804W08	3000	3x400	2,2	54	91/82*	77/68*	4500	2400	36
WPA-10-E-3-N	804W09	3000	3x400	3,0	54	91/87*	77/67*	6200	2450	50
WPA-11-E-3-N	804W12	3000	3x400	5,5	54	97/88*	83/74*	8050	2950	64
WPA-13-E-3-N	804W13	3000	3x400	7,5	54	99/90*	85/76*	10800	3300	85

* measurement has been carried out with the additional TK L=500 mm silencer installed at the fan inlet and outlet (for WPA-3-E-N apply TK L=370mm silencer).

1. Maximum temperature of the conveyed air is +60°C. Maximum temperature within the work area +40°C.

2. Maximum dustiness of the conveyed air should not exceed 0,3 g/m³.

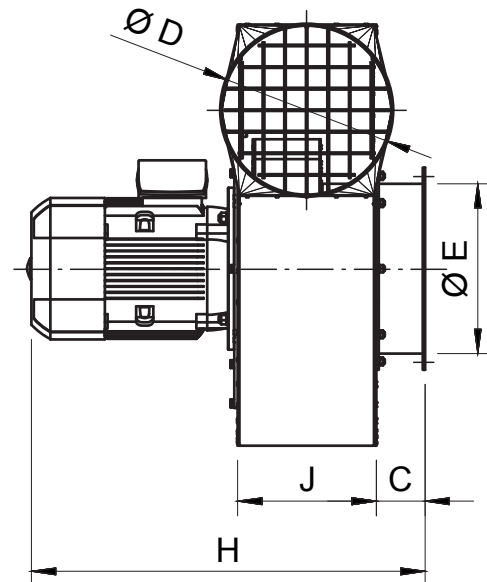
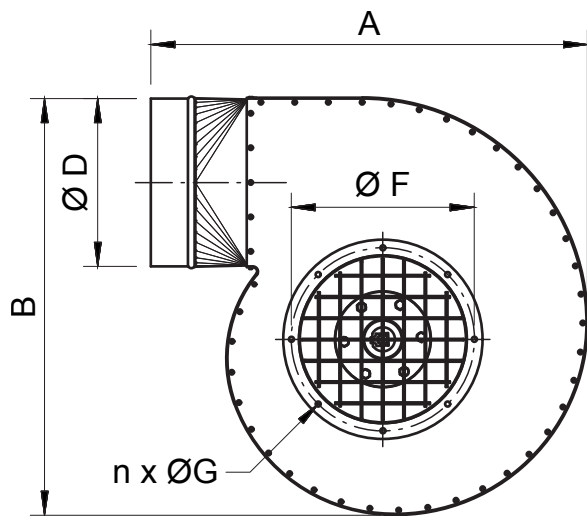

Dimensions

Type	A [mm]	B [mm]	C [mm]	D [mm]	E [mm]	F [mm]	n [pc.]	G [mm]	H [mm]	J [mm]
WPA-3-E-1-N	415	385	50	125	125	155	6	7,0	400	130
WPA-3-E-3-N										
WPA-5-E-1-N	485	480	60	160	160	194	6	7,0	420	140
WPA-5-E-3-N										
WPA-6-E-1-N	500	505	60	160	160	194	6	7,0	445	140
WPA-6-E-3-N										
WPA-7-E-1-N	550	520	60	200	160	194	6	7,0	460	155
WPA-7-E-3-N										
WPA-8-E-3-N	570	550	60	200	200	224	8	9,0	490	155
						234	6	7,0		
						246	8	9,0		
WPA-9-E-3-N	615	615	60	200	200	224	8	9,0	510	155
						234	6	7,0		
						246	8	9,0		
WPA-10-E-3-N	655	625	80	250	250	274	8	9,0	670	232
WPA-11-E-3-N	675	645	80	250	250	274	8	9,0	680	232
WPA-13-E-3-N	805	780	90	315	315	344	8	9,0	735	258